

C-C (8 : 10)

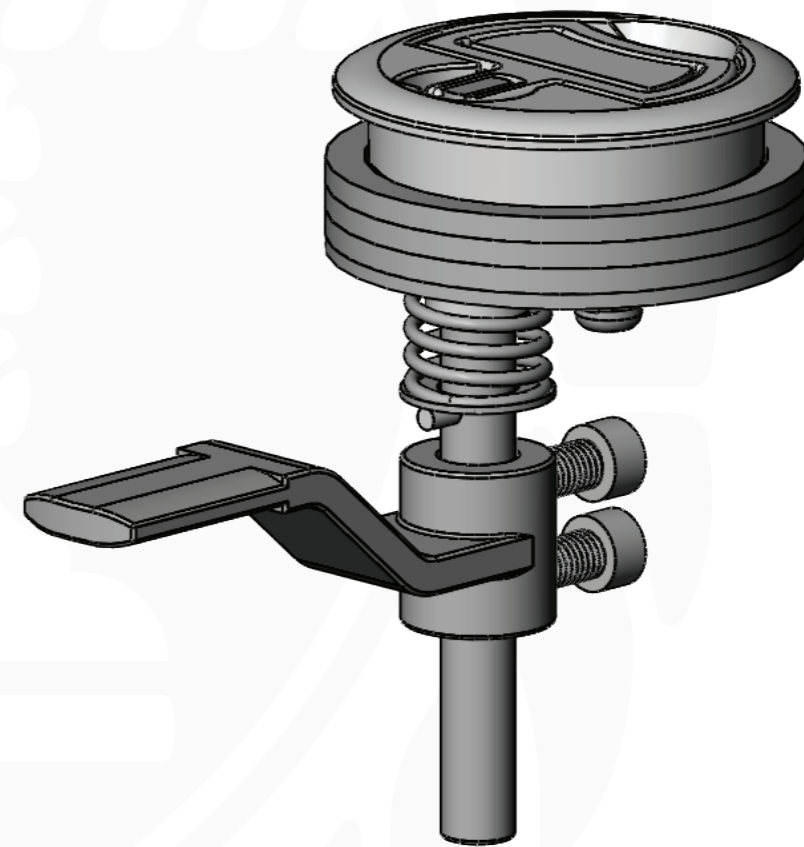

Sam Allen Wholesale
Marine, Outdoor Leisure & Industrial Accessories

385 Thynne Road, Morningside, Qld 4170 Australia
+61 7 3902 7222 | sales@samallen.com.au | www.samallen.com.au

Company :	Sam Allen Wholesale
Product Name :	Latch Compression HD 316G SS 60mm without Lock
Part No. :	29986
Unit Measure :	Millimeters
Material :	
Finish :	
Scale:	
Projection:	Paper: A3L

Drafted :		Date :	
Approved :		Date :	
Sheet :		of:	