

S5 MOUNTING INSTRUCTIONS

Applicable to tank w/o flange assembly

Preparation: 1. Tool: 4.0mm/ $\frac{1}{8}$ " drill, 40mm/ $1\frac{1}{2}$ " opener, pencil, electric hand drill.
2. Empty tank, clean tank with water, keep filler open.

Step 1:

Place gasket in the required hole area in tank, draw 1 big hole and 5 small holes by pencil. (Figure. 1)

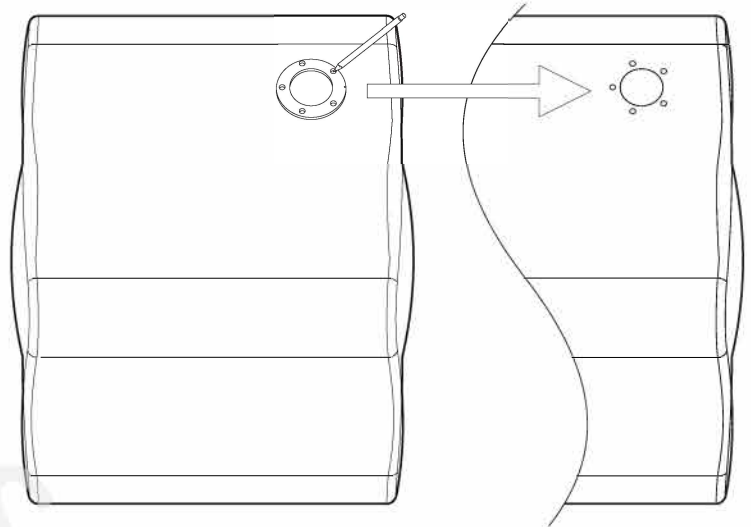

Figure. 1

Step 2:

Drill hole with 40mm opener (Figure. 2)

Step 3:

Drill 5 screw holes with $\phi 4.0\sim 4.2\text{mm}/\frac{1}{8}$ " drill, separately (Figure. 3)

Note: firstly, cover the big hole, and remove chips in small hole anytime, to avoid them drop into tank.

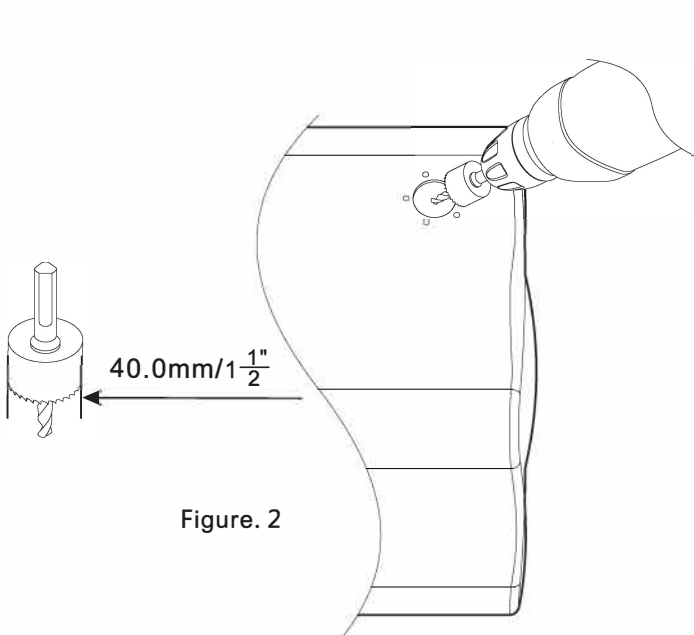

Figure. 2

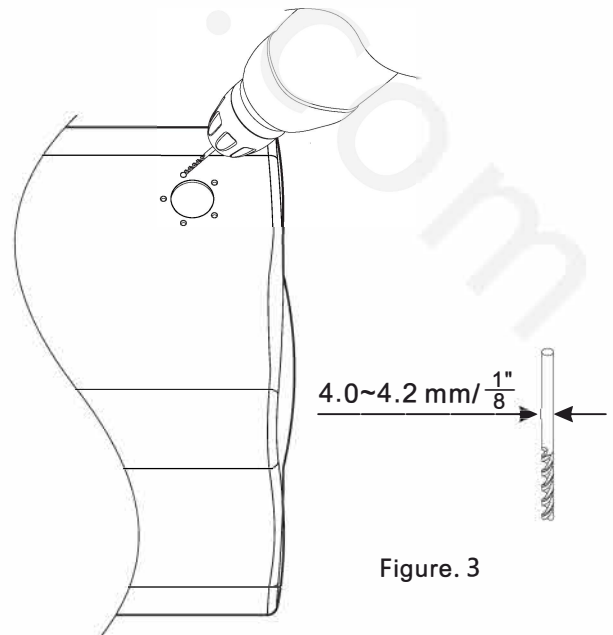

Figure. 3

S5 MOUNTING INSTRUCTIONS

Step 4:

Assemble into gasket & sensor, pay attention that directions of sensor's wire and gasket gap are the same (Figure. 4)

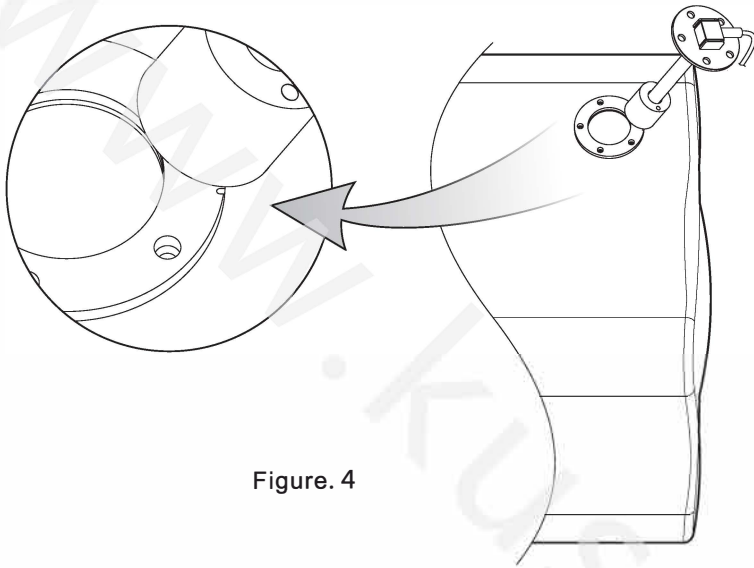

Figure. 4

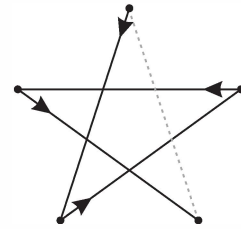

Diagram of star pattern

Step 5:

Fix the screw per "diagram of star pattern" firmly, and check whether they are in connecting gasket, done (Figure. 5)

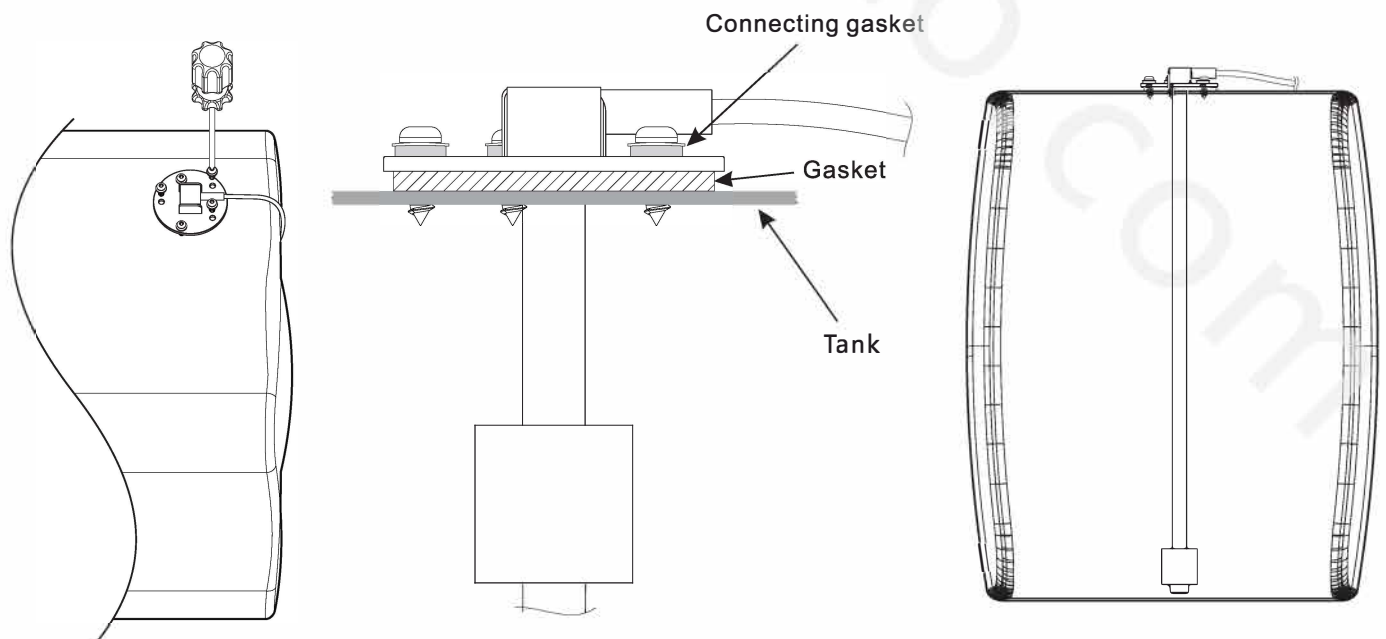

Figure. 5