



WORLD CLASS ANCHORS

THE ANCHOR OF CHOICE FOR AUSTRALIAN BOATIES



Manson Anchors has been anchoring Australian boats, keeping families safe and saving Australian lives since the late 1970's. It's an institutional brand in Australian boating circles, the anchor of choice for boat owners who are serious about keeping their family safe while at anchor.

Manson Anchors is also the anchor of choice for superyachts and large launches; giving runabouts, fizz boats and sailing novices the same quality and reliability that superyachts depend on.

Manson Anchors has the largest range of anchors in the world, whether it's robust galvanised steel or exquisitely polished stainless steel, choose an anchor made right here in Australasia.

With instant setting and instant holding power you can drop it, set it and forget it. Avoid constant resetting or embarrassing incidents. Anchor quickly and safely with the anchor brand your Mum and Dad relied on.





AUSTRALIAN SUPERYACHTS AND MOTORYACHTS

**BIGGEST
RANGE IN
THE WORLD**



**DROP
SET
FORGET**



IMPROVE YOUR BOATING EXPERIENCE

10 REASONS WHY YOU SHOULD CHOOSE A MANSON ANCHOR

1. Global Leader, World-class Technology

For nearly 50 years Manson Anchors has been keeping boaties safe, ensuring a good night sleep while anchored in every condition imaginable. Manson Anchors are the desired anchor brand, chosen by recreational and commercial skippers all over the world; from Sydney Harbour and Western Australian's rugged coastlines to Florida and the Mediterranean. Manson anchors are designed and manufactured by seasoned and proven experts that know how to keep you safe.

2. Supporting our Local Industry with Australasian Made

The complete Manson anchor range has been designed by marine engineers who understand how to anchor safely in the harsh waters of the Pacific. They are proudly crafted in New Zealand by Lloyd's Register approved welders using certified Lloyd's Register approved materials in a specialist facility, under the highest level of quality control. This means your anchor is not made cheaply by a company who has little respect for quality, the environment, or most importantly, what it means to anchor safely. Manson anchors are made by highly skilled craftsmen who build a safety product you can rely on, fabricated in either robust galvanized steel or exquisitely polished stainless steel.

3. World's Largest Range of Anchors

Not all boats are equal, so Manson Anchors make anchors to suit every situation - from small boats through to superyachts. Manson Anchors understand the unique challenges of anchoring and that big vessel or small, the most important thing is building a reliable anchor. The following pages illustrate the most common models Manson produce. Their superyacht range includes 5 models of which the Kedge is the most popular.

4. Quality Assurance

Manson Anchors are trusted to make anchors for the best shipyards in the world, building the most impressive superyachts and sophisticated Royal Australian Navy and US Navy vessels.

5. Instant Setting & Instant Holding

You go boating to enjoy, not be frustrated trying 3-4 times to set your anchor. The Manson team are experts in anchoring and have spent years building, testing and optimizing anchors for the fastest set and strongest possible hold in all conditions. When you anchor you need to be able to rely on your anchor. It should be a worry-free experience. You should be able to drop it, set it and forget it. When you use a Manson Anchor, you can take the fuss out of anchoring, sit back and enjoy your boating experience.

6. Lifetime Warranty

Manson's assembly techniques exceed all certification companies, and this means all Manson Anchors are given a lifetime warranty against breakage under normal use. Damage by deformation or bending is not covered by this guarantee.



7. New Generation and Traditional Anchors

Manson respect and understand old and new boat designs. This means Manson have a design that will suit your needs. Their new generation anchor range use materials and anchor designs suited to the latest boat designs. The traditional anchor range uses classic anchor designs like the Plough (CQR-type) or Ray (Bruce-type) anchor, which are more suited to older vessel designs.

8. Environmentally Conscious

Boating is only made possible by having a beautiful water playground to enjoy cruising, fishing and sailing. At Manson Anchors they are committed to playing their part in looking after this precious ecosystem. Manson's workplace complies with strict environmental regulations ensuring processes tuned to be as clean as possible. Strict controls prevent hazardous waste dumping, pollution of the air, sea and protected ecosystems. These regulations include the techniques and chemicals used. Manson Anchors galvanizing contains low levels of lead. High levels of lead are often used in the galvanization of anchors by other companies as it makes the galvanized anchor look shinier. This amount of exposure can have metamorphosis, neurological, and other developmental progressions on aquatic organisms. Additionally, Manson recycles all its waste. So, purchasing a Manson anchor means you are making a sustainable anchoring choice, choosing a brand that is committed to ensuring future generations will have the same idyllic boating memories that you do.

9. Class Society Type Approval

This means the material used to build Manson anchors has been supplied with certificates proving it is from a Lloyd's Register certified steel mill. It means the welders that fabricate the product are all individually Lloyd's Register certified and undergo yearly inspections and testing on their performance. The Manson Anchors welding procedures have been scrutinized by the Naval Architects at Lloyd's Register EMEA. Manson Anchors realize using cheap material could cost lives. They manufacture both stainless steel and galvanized anchors to all major classification societies.

10. Superyacht Class Certification

The classification classes to which Manson can build to are:

LR - Lloyd's Register

GL - Germanischer Lloyd

ABS - American Bureau of Shipping

DNV - Det Norske Veritas

RINA

BV- Bureau Veritas



Manson can meet new-build and refit class requirements.

11. Icons Represent



Certified to Lloyd's Register as a Super High Holding Power (SHHP) or High Holding Power (HHP) anchor.



Built by experts in New Zealand for the challenging waters that Australian boaties have to endure; quality and certified workmanship and material.



Guaranteed for life against breakage. Damage by deformation or bending is not covered by this guarantee.



Built in a country that puts the environment first and by a company that is committed to ensuring our future generations can enjoy creating memories in nature's water playground.





Manson Supreme Anchor (SHHP)

Manson Supreme Recommended Size Chart												
Boat Length (ft)	Anchor Weight (lb)											
	5lb	10lb	15lb	25lb	35lb	45lb	60lb	80lb	100lb	125lb	150lb	
10ft	≤ 1T	≤ 2T										
13ft	≤ 0.5T	≤ 2T	≤ 5T									
16ft		≤ 1T	≤ 5T									
20ft		≤ 1T	≤ 4T									
23ft		≤ 0.5T	≤ 4T									
26ft			≤ 4T	≤ 7T	≤ 10T							
30ft			≤ 3T	≤ 6T	≤ 9T	≤ 16T						
33ft			≤ 2T	≤ 5T	≤ 9T	≤ 15T	≤ 20T					
39ft				≤ 4T	≤ 8T	≤ 14T	≤ 19T	≤ 30T				
45ft				≤ 3T	≤ 6T	≤ 13T	≤ 18T	≤ 25T	≤ 35T			
52ft						≤ 12T	≤ 17T	≤ 20T	≤ 25T	≤ 50T	≤ 70T	
59ft							≤ 16T	≤ 20T	≤ 25T	≤ 40T	≤ 60T	
66ft							≤ 12T	≤ 20T	≤ 25T	≤ 40T	≤ 60T	
72ft								≤ 15T	≤ 25T	≤ 40T	≤ 60T	
79ft									≤ 20T	≤ 30T	≤ 50T	
85ft										≤ 20T	≤ 40T	

Lloyd's Register rules apply to anchor sizes. This guide is not intended to replace or supercede any class or maritime sizing recommendations and they need to be checked before final selection is made.

Boat Weight (T)

NOTE: Multihull and offshore cruising vessels should use one size up from the recommendation.

Anchor - Manson Supreme (SHHP)



- Conforms to most common bow roller designs and self-launches.
- Rollbar ensures anchor rolls itself to adopt the correct setting position.
- Twin slots on the fixed shank enable use in all seabeds. If using the rockslot, (long slot) the shackle can slide forward and lift the anchor out forward if it becomes fouled.
- High tensile steel shank made from 800mpa steel - 25% stronger than any other anchor.
- Sharp spearhead assists anchor to pierce the toughest seafloors, ensuring greater penetration.
- Lateral flaps enable the anchor to set immediately.
- Reinforced double-skinned laminated nose, strengthens the forward section where most loading is concentrated.
- Certified to Lloyd's Register as a Super High Holding Power (SHHP) anchor.
- Available in galvanised or highly polished stainless steel.

NOTE: Some sizes of the stainless steel versions are buy-in only (lead time approx. 16 weeks).

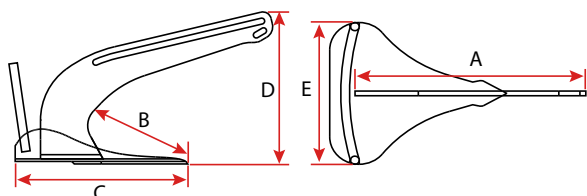

Galvanised							
Part No.	Weight		Length (A) (mm)	Fluke Length Inner (B) (mm)	Fluke Length Outer (C) (mm)	Depth (D) (mm)	Fluke Width (E) (mm)
	(kg)	(lb)					
124070	2	5	340	140	250	225	210
124072	4.5	10	430	175	310	275	260
124074	7	15	470	195	350	310	285
124076	11	25	550	235	415	360	350
124078	16	35	620	265	465	415	360
124080	21	45	685	295	520	460	410
124082	27	60	750	315	570	485	450
124084	37	80	850	360	650	560	500
124086	45	100	905	370	675	560	525
124088	57	125	960	400	715	620	600
124090	68	150	1025	415	735	655	615
124092	80	175	1075	455	780	685	675

Also available in sizes 225lb to 375lb - POA

Stainless Steel							
Part No.	Weight		Length (A) (mm)	Fluke Length Inner (B) (mm)	Fluke Length Outer (C) (mm)	Depth (D) (mm)	Fluke Width (E) (mm)
	(kg)	(lb)					
124324	7	15	470	195	350	310	285
124326	11	25	550	235	415	360	350
124328	16	35	620	265	465	415	360
124330	21	45	685	295	520	460	410
124332	27	60	750	315	570	485	450
124334	37	80	850	360	650	560	500
124336	45	100	905	370	675	560	525
124338	57	125	960	400	715	620	600
124340	68	150	1025	415	735	655	615
124342	80	175	1075	455	780	685	675

BUY-IN ONLY

BUY-IN ONLY

BUY-IN ONLY

BUY-IN ONLY

BUY-IN ONLY

BUY-IN ONLY

BUY-IN ONLY

BUY-IN ONLY

BUY-IN ONLY

Also available in sizes 225lb to 375lb - POA



Boat Length (ft)	Manson Boss Recommended Size Chart										
	Anchor Weight (lb)										
	5lb	10lb	15lb	25lb	35lb	45lb	60lb	80lb	100lb	125lb	150lb
10ft	≤ 1T	≤ 2T									
13ft	≤ 0.5T	≤ 2T	≤ 5T								
16ft		≤ 1T	≤ 5T								
20ft		≤ 1T	≤ 4T								
23ft		≤ 0.5T	≤ 4T								
26ft			≤ 4T	≤ 7T	≤ 10T						
30ft			≤ 3T	≤ 6T	≤ 9T	≤ 16T					
33ft			≤ 2T	≤ 5T	≤ 9T	≤ 15T	≤ 20T				
39ft				≤ 4T	≤ 8T	≤ 14T	≤ 19T	≤ 30T			
45ft				≤ 3T	≤ 6T	≤ 13T	≤ 18T	≤ 25T	≤ 35T		
52ft						≤ 12T	≤ 17T	≤ 20T	≤ 25T	≤ 50T	≤ 70T
59ft							≤ 16T	≤ 20T	≤ 25T	≤ 40T	≤ 60T
66ft							≤ 12T	≤ 20T	≤ 25T	≤ 40T	≤ 60T
72ft								≤ 15T	≤ 25T	≤ 40T	≤ 60T
79ft									≤ 20T	≤ 30T	≤ 50T
85ft										≤ 20T	≤ 40T

Boat Weight (T)

NOTE: Multihull and offshore cruising vessels should use one size up from the recommendation.

Anchors - Manson Boss

Part No.	Weight		Length (A) (mm)	Depth (B) (mm)	Width (C) (mm)	Fluke Length (D) (mm)	Fluke Length Inner (E) (mm)	Shank Length (F) (mm)	Shank Spacer (G) (mm)
	(kg)	(lb)							
	Galvanised								
124130	2	5	460	232	258	272	179	297	8
124132	4.5	10	600	300	334	353	231	386	10
124134	7	15	689	342	382	405	266	443	12
124136	11	25	836	414	462	491	321	537	12
124138	16	35	937	463	516	551	360	602	14
124140	21	45	1002	498	554	589	385	643	14
124142	27	60	1117	554	617	658	430	718	18
124144	37	80	1200	599	663	706	462	771	18
124146	45	100	1264	630	698	744	486	813	18
124148	57	125	1397	698	775	828	541	904	18
124150	68	150	1411	707	779	831	543	908	24
124152	80	175	1503	751	828	886	578	967	24

Also available in sizes 225lb to 375lb - POA

Part No.	Weight		Length (A) (mm)	Depth (B) (mm)	Width (C) (mm)	Fluke Length (D) (mm)	Fluke Length Inner (E) (mm)	Shank Length (F) (mm)	Shank Spacer (G) (mm)
	(kg)	(lb)							
	Stainless Steel								
124364	7	15	689	342	382	405	266	443	12
124366	11	25	836	414	462	491	321	537	12
124368	16	35	937	463	516	551	360	602	14
124370	21	45	1002	498	554	589	385	643	14
124372	27	60	1117	554	617	658	430	718	18
124374	37	80	1200	599	663	706	462	771	18
124376	45	100	1264	630	698	744	486	813	18
124378	57	125	1397	698	775	828	541	904	18
124380	68	150	1411	707	779	831	543	908	24
124382	80	175	1503	751	828	886	578	967	24

Also available in sizes 225lb to 375lb - POA



- Fits most common bow rollers, designed specifically for powerboats.
- Angled winglets dig the anchor into the seabed for immediate alignment and setting.
- Reinforced double-skinned laminated toe, strengthens the forward section of the anchor when it attacks the seabed.
- The anchor presses the concave shape into the fluke, ensuring the anchor cups the seabed and sets much faster.
- Raised trim flaps improve the holding power by forcing the flukes downwards creating a 28% deeper setting than other new-generation anchors.
- Manson Shackle Preventor™ has one slot in the shank with two docking stations for use in all sea beds. It quickly unscrews and docks on the alternate station to transform the anchor from a fixed shank to a sliding shank for operation in foul ground.
- The shank clearance is streamlined to conform to power boat fairleads and bow rollers.
- High tensile steel shank made from 800mpa steel.
- Regularly available in galvanised steel, but also in black painted steel or highly polished stainless steel to order.

NOTE: Stainless steel versions, large galvanised and black painted anchors are buy-in only (lead time approx. 16 weeks).

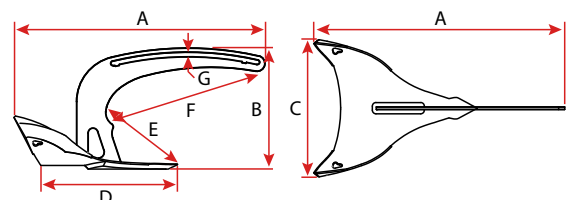



Manson Plough Anchor (HHP)

Boat Length (ft)	Manson Plough Recommended Size Chart										
	Anchor Weight (lb)										
	10lb	15lb	20lb	25lb	35lb	45lb	60lb	80lb	100lb	120lb	150lb
10ft	≤ 1T	≤ 2T									
13ft	≤ 0.5T	≤ 2T	≤ 5T								
16ft		≤ 1T	≤ 5T								
20ft		≤ 1T	≤ 4T								
23ft		≤ 0.5T	≤ 4T								
26ft			≤ 4T	≤ 7T	≤ 10T						
30ft			≤ 3T	≤ 6T	≤ 9T	≤ 16T					
33ft			≤ 2T	≤ 5T	≤ 9T	≤ 15T	≤ 20T				
39ft				≤ 4T	≤ 8T	≤ 14T	≤ 19T	≤ 30T			
45ft				≤ 3T	≤ 6T	≤ 13T	≤ 18T	≤ 25T	≤ 35T		
52ft						≤ 12T	≤ 17T	≤ 20T	≤ 25T	≤ 50T	≤ 70T
59ft							≤ 16T	≤ 20T	≤ 25T	≤ 40T	≤ 60T
66ft							≤ 12T	≤ 20T	≤ 25T	≤ 40T	≤ 60T
72ft								≤ 15T	≤ 25T	≤ 40T	≤ 60T
79ft									≤ 20T	≤ 30T	≤ 50T
85ft										≤ 20T	≤ 40T

Lloyd's Register rules apply to anchor sizes. This guide is not intended to replace or supercede any class or maritime sizing recommendations and they need to be checked before final selection is made.

Boat Weight (T)

NOTE: Multihull and offshore cruising vessels should use one size up from the recommendation.

Anchor - Manson Plough (HHP)



- Traditional anchor with proven performance in the widest variety of weather and seabeds.
- Hinged shank improves the scope of movement of chain.
- Weighted tip ensures the anchor digs in on the first attempt and resets if dislodged in strong conditions.
- Wings ensure the anchor self corrects.
- Certified to Lloyd's Register as a High Holding Power (HHP) anchor.

NOTE: Stainless steel versions and larger galvanised anchors are buy-in only (lead time approx. 16 weeks).

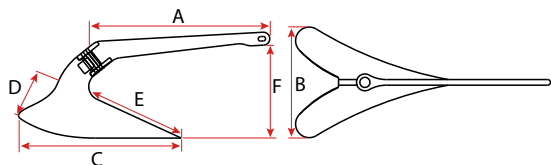

Part No.	Weight		Length (A) (mm)	Width (B) (mm)	Fluke Length Outer (C) (mm)	Fluke Height (D) (mm)	Fluke Length Inner (E) (mm)	Depth (F) (mm)
	(kg)	(lb)						
124000	4.5	10	445	225	335	60	205	250
124002	7	15	495	230	365	65	255	250
124004	9	20	570	265	415	90	215	285
124006	12	25	570	280	430	90	240	290
124008	14	30	640	295	455	95	250	320
124010	16	35	640	305	470	95	275	320
124012	18	40	735	335	500	85	295	340
124014	21	45	735	355	520	90	320	345
124016	24	50	735	355	540	95	340	375
124018	27	60	835	385	590	105	370	385
124020	36	80	840	445	680	115	420	435
124022	45	100	925	510	770	120	460	470
124024	55	120	925	510	770	120	460	470
124026	68	150	935	530	790	180	490	490
124028	82	180	935	530	790	180	490	490
124030	91	200	965	605	825	200	515	510

Also available in sizes 250lb and 300lb - POA.

Part No.	Weight		Length (A) (mm)	Width (B) (mm)	Fluke Length Outer (C) (mm)	Fluke Height (D) (mm)	Fluke Length Inner (E) (mm)	Depth (F) (mm)
	(kg)	(lb)						
124242	7	15	495	230	365	65	255	250
124244	9	20	570	265	415	90	215	285
124246	12	25	570	280	430	90	240	290
124248	14	30	640	295	455	95	250	320
124250	16	35	640	305	470	95	275	320
124252	18	40	735	335	500	85	295	340
124254	21	45	735	355	520	90	320	345
124256	24	50	735	355	540	95	340	375
124258	27	60	835	385	590	105	370	385
124260	36	80	840	445	680	115	420	435
124262	45	100	925	510	770	120	460	470
124264	55	120	925	510	770	120	460	470
124266	68	150	935	530	790	180	490	490
124268	82	180	935	530	790	180	490	490
124270	91	200	965	605	825	200	515	510

Also available in sizes 250lb and 300lb - POA.



Manson Ray Anchor (HHP)

Manson Ray Recommended Size Chart									
Boat Length (ft)	Anchor Weight (kg)								
	10kg	15kg	20kg	25kg	30kg	35kg	40kg	50kg	65kg
10ft									
13ft	≤ 5T								
16ft	≤ 5T								
20ft	≤ 4T								
23ft	≤ 4T								
26ft	≤ 4T	≤ 7T	≤ 10T						
30ft	≤ 3T	≤ 6T	≤ 9T	≤ 16T					
33ft	≤ 2T	≤ 5T	≤ 9T	≤ 15T	≤ 20T				
39ft		≤ 4T	≤ 8T	≤ 14T	≤ 19T	≤ 30T			
45ft		≤ 3T	≤ 6T	≤ 13T	≤ 18T	≤ 25T	≤ 35T		
52ft				≤ 12T	≤ 17T	≤ 20T	≤ 25T	≤ 50T	≤ 70T
59ft					≤ 16T	≤ 20T	≤ 25T	≤ 40T	≤ 60T
66ft					≤ 12T	≤ 20T	≤ 25T	≤ 40T	≤ 60T
72ft						≤ 15T	≤ 25T	≤ 40T	≤ 60T
79ft							≤ 20T	≤ 30T	≤ 50T
85ft								≤ 20T	≤ 40T

Lloyd's Register rules apply to anchor sizes. This guide is not intended to replace or supersede any class or maritime sizing recommendations and they need to be checked before final selection is made.

Boat Weight (T)

NOTE: Multihull and offshore cruising vessels should use one size up from the recommendation.

Anchor - Manson Ray (HHP)

Galvanised					
Part No.	Weight		Length (A) (mm)	Depth (B) (mm)	Width (C) (mm)
	(kg)	(lb)			
124040	10	22	570	320	390
124042	15	33	680	380	445
124044	20	44	710	400	465
124046	25	55	710	400	465
124048	30	66	810	455	540
124050	35	77	810	455	540
124052	40	88	860	485	590
124054	50	110	932	525	640
124056	65	143	969	657	539
124058	80	176	1060	595	710

Also available in sizes 200lb and 330lb - POA.

Stainless Steel					
Part No.	Weight		Length (A) (mm)	Depth (B) (mm)	Width (C) (mm)
	(kg)	(lb)			
124280	10	22	570	320	390
124282	15	33	680	380	445
124284	20	44	710	400	465
124286	25	55	710	400	465
124288	30	66	810	455	540
124290	35	77	810	455	540
124292	40	88	860	485	590
124294	50	110	932	525	640
124296	65	143	969	657	539
124298	80	176	1060	595	710

Also available in sizes 200lb and 330lb - POA.



BUY-IN ONLY

- Wings ensure the anchor sets quickly and resets in a variety of bottom conditions.
- Fabricated in the highest quality steel plate - not cast.
- Weighted toe and curved flukes to ensure the anchor lands the right way up for immediate setting.
- Certified to Lloyd's Register as a High Holding Power (HHP) anchor.

NOTE: Stainless steel versions and larger galvanised anchors are buy-in only (lead time approx. 16 weeks).

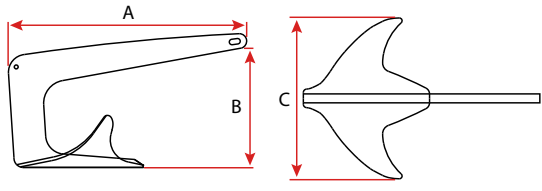



Manson Racer Anchor

Boat Length (ft)	Manson Racer Recommended Size Chart									
	Anchor Weight (lb)									
	2.2lb	2.7lb	3.3lb	7.5lb	8.0lb	10lb	23lb	25lb	32lb	35lb
10ft	R1									
13ft	R1									
16ft	R1	R2								
20ft		R2	R3							
23ft			R3							
26ft			R3	R4						
30ft				R4	R5					
33ft					R5	R6				
39ft						R6	R7			
45ft							R7	R8		
52ft								R8	R9	
59ft									R9	R10
66ft										R10
72ft										R10

Racer Anchor Model

Anchor - Manson Racer

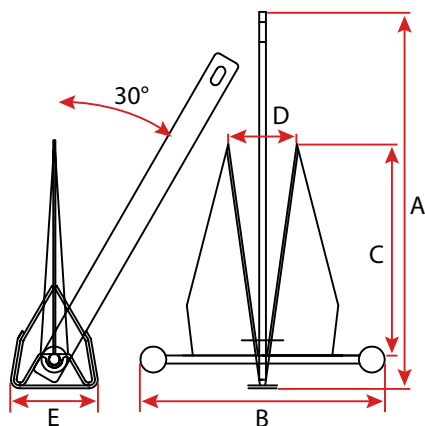

Part No.	Weight		Model	Length (A) (mm)	Width (B) (mm)	Fluke Length (C) (mm)	Fluke Split (D) (mm)	Fluke Width (E) (mm)
	(kg)	(lb)						
124440	1	2.2	R1	430	260	250	85	115
124442	1.2	2.7	R2	490	280	275	90	115
124444	1.5	3.4	R3	545	315	310	100	115
124446	3.4	7.5	R4	660	380	375	120	155
124448	3.6	8	R5	725	420	410	130	155
124450	4.5	10	R6	800	520	460	170	155
124452	11	23	R7	890	615	545	180	185
124454	12	25	R8	985	730	575	190	185
124456	15	32	R9	1080	755	635	210	235
124458	16	35	R10	1175	830	700	230	235

BUY-IN ONLY

- High-tensile anodised aluminium anchor, specifically tailored for racing yachts of all sizes.
- Reduced weight assures easier handling, storage and great weight saving potential.
- Hard wearing stability discs reduce the width of the lower balance bar and encourage the anchor to set faster and resist rotation when embedded in the sea floor.
- Folds flat for easy storage.
- The sharpened tips assist the anchor to pierce the toughest seabeds, ensuring greater penetration.

NOTE: R9 and R10 sizes are buy-in only (lead time approx. 16 weeks).

Racer Anchor Bags	
Part No.	Description
124460	Racer Bag Small suits 124440 / 124442 / 124444
124462	Racer Bag Large suits 124446 / 124448 / 124450

- Heavy duty woven nylon fabric bag foam padded and polyester fabric lined.
- Protects both the anchor and the vessel from sharp fluke tips.
- Heavy duty nylon zip closure.
- Webbing carry handle.



Anchor - Manson Kedge (HHP)



Galvanised									
Part No.	Weight		Length (A) (mm)	Width (B) (mm)	Fluke Length (C) (mm)	Fluke Width (D) (mm)	Crown (E) (mm)	Shank Width (F) (mm)	Depth (G) (mm)
	(kg)	(lb)							
124110	50	110	720	430	510	525	155	10	255
124111	75	165	810	480	570	590	170	50	285

BUY-IN ONLY
BUY-IN ONLY

Also available in sizes 100kg to 200kg - POA.

Manson produces 5 styles of Superyacht anchors of which the Kedge is the most popular design.

Stainless Steel									
Part No.	Weight		Length (A) (mm)	Width (B) (mm)	Fluke Length (C) (mm)	Fluke Width (D) (mm)	Crown (E) (mm)	Shank Width (F) (mm)	Depth (G) (mm)
	(kg)	(lb)							
124310	50	110	720	430	510	525	155	10	255
124311	75	165	810	480	570	590	170	50	285

BUY-IN ONLY
BUY-IN ONLY

- Ideal for larger craft and specified by many of the world's finest superyachts the Manson Kedge Anchor is manufactured within exacting standards to exceed all certifying requirements.
- Manufactured in both stainless steel and galvanised, these anchors perform exceptionally well on larger vessels.
- Traditionally stowed on either side of the bow on larger craft, these anchors can be a real showcase – housed in one of the most visible parts of a vessel. The Manson Kedge Anchor has been tested and proven all around the world.
- Manson Kedge Anchors are Lloyd's Register Type Approved as HHP (High Holding Power).

NOTE: Manson Kedge Anchors are buy-in only (lead time approx. 16 weeks).

Also available in sizes 100kg to 200kg - POA.

Manson produces 5 styles of Superyacht anchors of which the Kedge is the most popular design.

